



# X-Ray Baggage Scanner

## TH100100

### Product highlights

- \* Multilingual operation
- \* Automatic built in test and self diagnosis
- \* Secure access Key
- \* Threat alert and material classification
- \* Auto archiving
- \* Energy saving design
- \* One key turn off
- \* Drugs and explosives inspection
- \* Indication of the date and time
- \* Baggage counter

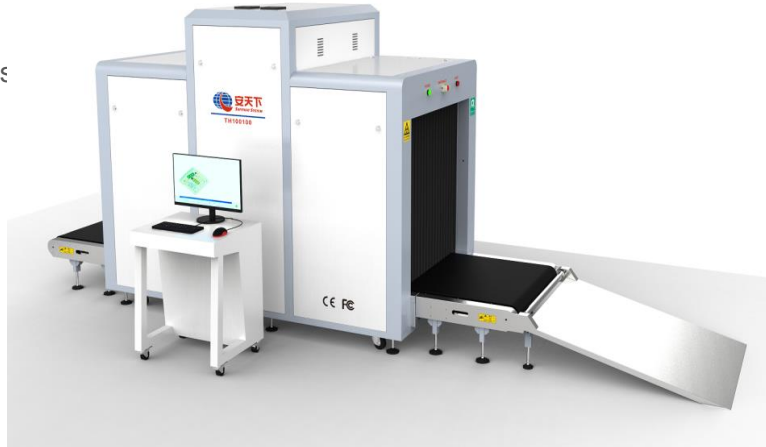

### Physical Specifications

Unit weight (kgs)	940
Unit size (mm)	3629(L)*1295(W)*1916(H)
after packed in wooden pallet -	
Gross weight (kgs)	1100
Packing size	#1: 285*142*212cm #2: 75*65*99cm

### General Specifications

Tunnel size(mm)	1000(L)*1000(W)
Conveyor Speed(m/s)	0.22
Conveyor height(mm)	341
Conveyor Max Load(kgs)	200
X ray dose per each inspection	$\leq 3.5 \mu\text{Gy}$
X ray leakage	$< 1 \mu\text{Gy/h}$ at any point 5 centimeters outside the external surface
Penetration	34 mm steel

Wire Resolution	AWG36
Penetration Resolution	AWG30
Spatial resolution:	Horizontal:dia 2.0mm, Vertical: dia 2.0mm
Power Consumption	max. 1KW
Noise	<60 dB
Film Safety	Guarantee ASA/ISO1600 Film

## X-ray Generator (single)

Anode Voltage	160 KV
Ray direction	Downward
Cooling / Duty Cycle	Sealed oil cooling /100%

## Image System

X-ray Sensor	L-Shaped Photodiode Array, 12bit deep
Images process	24bit real time processing ,4colors analysis, Images displayed marked date and ID No., Count the number of bags
Image display	High resolution of 1920*1080 pixel; Image Grey Level: 65536
Image Enhancement	1-32 times enlargement continuity, Color/BW, negative, high/low penetration enhancement, brightening, darkening, gray level scan, super enhancement, elimination of organics/inorganics, local enhancement, pseudo color processing, edge enhancement, etc.
Explosives & Narcotics Detection	Suspicious organics highlight(atomic number Zeff=7,8,9)
Suspicious Alarm	Alarm and box line the suspicious objects including hard to penetrate material, explosives and drugs
Threat Image Projection(TIP)	Inserting fictional, but realistic images of threat items into baggage during screening operation, for maintenance of vigilance, as well as training and assessment of image identification capability
Image Recall	30 images recallable
Image Archive	Up to 10,000 images stored automatically, enable transferring to USB disk, and converting to JPG format
Miscellaneous Functions	Time/date display, counters, user management, system-on/X-ray-on timers, power on self test, built-in diagnostic facilities, dual-direction scanning, system log, system standby and stimulant training, etc.

Options Intelligent roller, network, etc.

## Operating Environment

Operation temperature/Humidity	5°C-40°C / 0%-90%(non-condensing)
Storage Temperature/Humidity	-20°Cto 60°C / 10%-90%(non-condensing)
Operation Power	220VAC(±10%) 50±3Hz (Options: 110-120V, 230-240V, 60Hz)
Stabilizer and UPS	Optional

## Computer and other

Monitor	One 21.5-inch LCD monitor, 1920*1080, one console desk
RAM	1GB
Keyboard	Special designed
System	Embedded Linux operating system, multi core ARM, stable and reliable
Electric roller	Three-phase

## Compliance

International	* ISO19001; ISO14001; ISO45001 * CE RoHS * FDA FCC
---------------	--

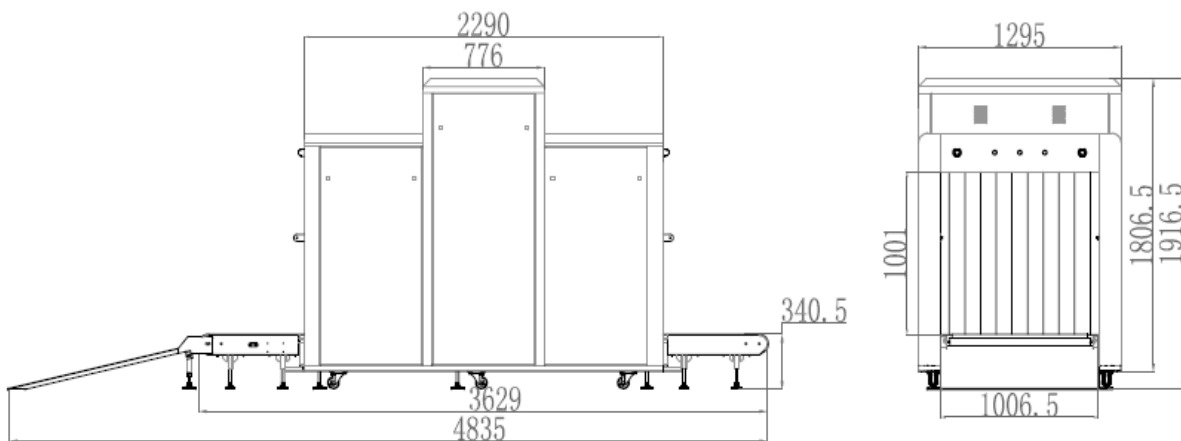

### SAFEWAY INSPECTION SYSTEM COMPANY LIMITED

Add: Building A&E, Qifeng Digital Park, Baili Road, Nanwan Street, LongGang District, Shenzhen China  
Tel: 0755-84656535 Email: info@chinasafeequipment.com www.chinasafeequipment.com